

Modelo

F16-600C

MONTACARGA

KONECRANES

MT0011

CARACTERISTICAS

Marca	KONECRANES
Modelo	F16-600C
Serie	M12183
Año de fabricación	2019
Capacidad	16 T
Peso neto	17600 KG
Altura	3.66 m

MOTOR

Motor	VOLVO (TAD-551-VE)
Serie	7005337334
Potencia	129KW
RPM	2300
Tipo de inyección	Inyección directa
Número de cilindros	06

LLANTAS Y NEUMÁTICOS

Tipo	Acero
Neumático	12.00X20-18PR
Marca	DUNLOP
Nro. Neumáticos	6

DIMENSIONES

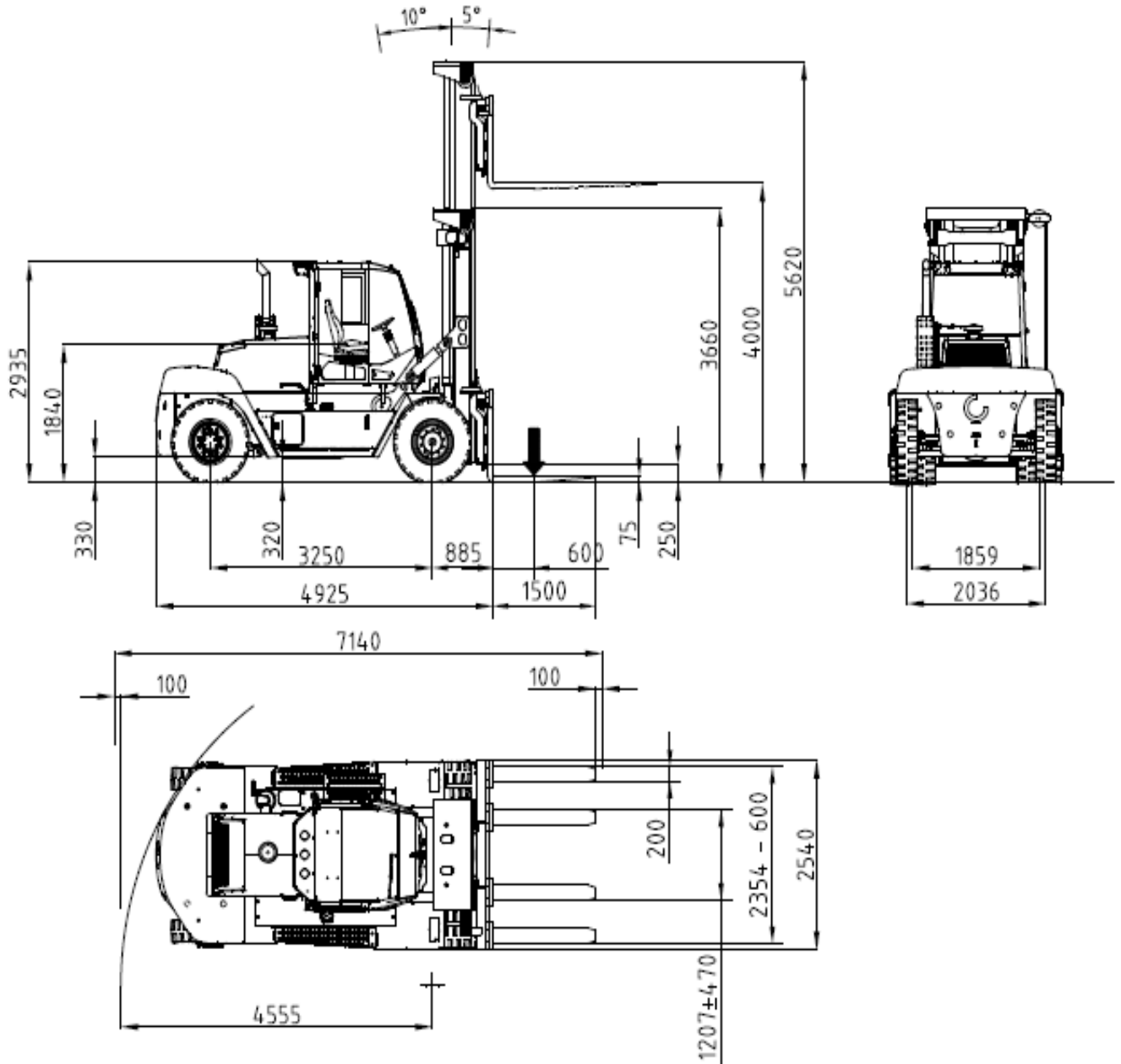

#

DIMENSIONES

Forks	Dim: 2.400 x 200 x 75 mm		
	Serial No: MSI	Left: 153283-1-1	Right: 153283-1-1
Options			
Technical data	Lift capacity	Lifting height	Load centre
	16.000 kg	4.000 mm	600 mm
	12.400 kg	4.000 mm	900 mm
	10.100 kg	4.000 mm	1.200 mm
	8.400 kg	4.000 mm	1.500 mm
	Lifting height	4.000 mm	
	Height max. low mast	3.645 mm	
	Height max. ext. mast	5.600 mm	
	Tilting angle F/R	5° / 10°	
	Length	4.880 mm	
	Width	2.500 mm	
	Height over cab	2.935 mm	
	Wheel base	3.250 mm	
Turning radius	4.555 mm		
Weights	Total weight	17.400 kg	
	Drive axle	8.000 kg	
	Steering axle	9.400 kg	

DIAGRAMA DE CARGA

